

With boltable sides.

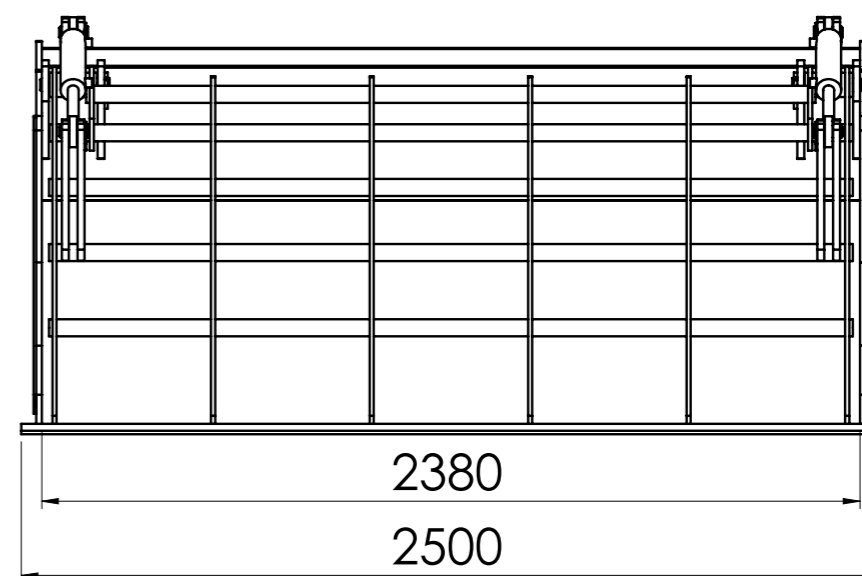
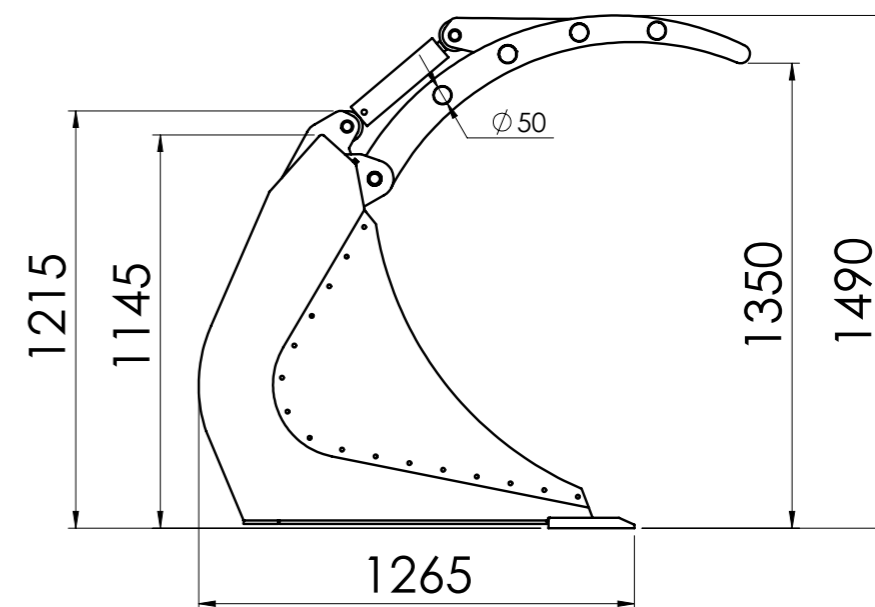

6	Bottom bar	S355	10x100 mm
5	Side member	S355	8 mm
4	Side	S355	16 mm
3	Ribs	S355	12 mm
2	Bottom plate	S355	8 mm
1	Front edge	HB 500	30x250x2500 mm

NO.	TITLE	MATERIAL	DESCRIPTION
-----	-------	----------	-------------

	Volume	2000 L	Mass	1200 kg	Scale
--	--------	--------	------	---------	-------

Drawn	Teet Toming	Name	
Checked		BWG491	
Approved			

	Sheet	Date
	1 of 1	23.11.2015